

PORTABLE REFRESHABLE E-BRAILLE

M.A.Raja¹ A.Arunya² DiptiYadav³ G.Kanitha⁴ R.Maheshwari⁵

Assistant Professor, Department of Electronics and Communication,
Park college of Engineering and Technology,
Coimbatore, India

rajalecturer@gmail.com, arunyaa48@gmail.com ydipti02@gmail.com gkans07@gmail.com
mahesh07er@gmail.com

ABSTRACT

Braille is an important language used by the blind to read and write. It is vital for communication and educational purposes. The scarcity of accessible information mediums for visually impaired people is recognized by many international organizations. But with advancement many products developed, failed to address issues like cost, portability, expanse in mass society and education etc. In order to overcome the above said challenges we design a device called "Portable Refreshable e-Braille" which is able to read eBooks that are stored in microSD cards, reads SMSes from mobile phones over Bluetooth and display them as Braille. It is a portable, simple and versatile device for visually impaired that eases their difficulties in reading any sort of literary material.

Keyword - Bluetooth, E-Braille, MicroSD Portability

1. INTRODUCTION

Braille is a tactile writing language of raised dots, mainly used by the blind and visually impaired. It is developed for our haptics perception, a combination of the sense of touch, movement and finger pressure.

The dots are arranged in cells. Every cell consists of a majority of six dots in a small rectangle. A finger tip can feel the whole cell at once. [1] The system gives 63 combinations and one blank step. In six dots Braille, each cell consists of a 3x2 matrix of raised dots. Each cell is made up of six raised dots that relate to a letter, number or character. These dots are raised roughly 0.9mm by pressure from a cylindrical pin, causing identification underneath the thick paper. The existing system lacks portability with insufficient power management. The visually impaired do not have access to e-documents and sms without through knowledge and training to how to use the device with simplicity of operation [6]. Current system uses relays to generate patterns and draws more current as relays are used. Due to the use of embossing mechanism in the earlier Braille display

Typewriter model, the weight of embossing tool will slow the rotational speed of stepper motor however light this may be, and also add to the cost of product [11].

In this proposed portable electronic Braille system, the main objective is to eliminate the barriers that prevent visually challenged children and adults from using the embedded -tech device due to their lack of knowledge to use computers. Thus the existing Accessibility features were first analyzed and upon knowing what more is to be done to help them reach the e-documents with ease ,all those constraints were taken into account by using embedded technology with serial peripheral communication, wireless transceiver, Bluetooth module, rechargeable and portable batteries etc..

In our proposed system, the device possesses a microSD socket for accessing stored eBooks, as well as a capacitive touch interface for browsing them. The device can also interface with mobile phones via Bluetooth and a custom application, which will capture SMS for display in Braille [4][5]. The device currently consists of two Braille cells, and is designed such that more cells can be added with only minor modifications to the entire

design. All these serve to make the device more accessible to the visually impaired. Our target is to have Braille cells whose dimensions conform to an established, widely used specification [7]. The refresh speed of the cells must be at least as fast as the mean reading speed of 7.5 characters. Since the device is to be portable, we aim to create a rechargeable device with at least one hour battery life.

Our system consists of microcontroller, Braille interface, wireless transceiver, sensor and power supply. The controller encodes alphanumeric characters into control signals for servos. It receives data from external sources, performs gesture recognition on sensor data. It uses SPI and PC communication.

2. DESIGN ARCHITECTURE

The design architecture can be analyzed based on two platforms: hardware and software. The controller is implemented as two separate PCBs. One, is denoted as the sense board, is responsible for interfacing with the wireless transceiver, removable memory, and sensor. The other, denoted as the control board, is responsible for interfacing with the power gauging IC and the 12 servos. ATMEGA328 is chosen to be the microcontroller as it is compatible with the Arduino Software Libraries. The boards functions as:

- To display Braille text, the sense board would fetch ASCII text from the removable memory or the wireless transceiver
- Send them to the control board via serial interface.
- The control board will then convert the ASCII characters into servo control signals to actuate the Braille pins.
- New boards will be connected to the same serial port and be given a unique ID, allowing the sense board to address each control board individually.

The purpose of the sense board is to direct the control board to display alphanumeric characters on the Braille interface based on data read from the micro-SD card or received from the Bluetooth receiver. It is also responsible for performing gesture recognition based on data from the from the capacitive touch board.

2.1 Hardware Architecture

The hardware design consists of:

2.1.1 Braille Interface

It consists of a plate on top of two stacks of six servos. Each servo is responsible for lowering and raising a pin, which will emerge through perforations on the top plate to form a Braille dot.

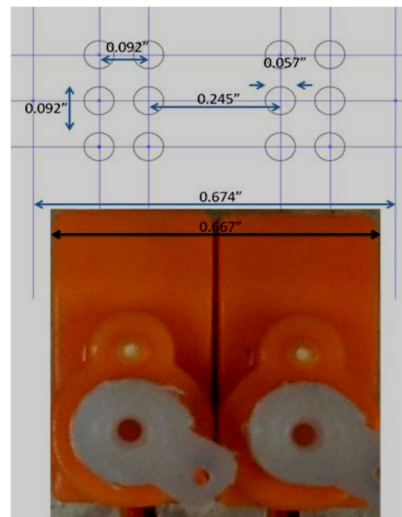

Figure. 1 Dimensions of servo

The perforations serve as guides for the pins, restricting their motion along the vertical axis and together they form two six-dot Braille cells which users will touch. Sub-micro servos are chosen for their small size and weight and the ability to maintain their positions when no power is supplied. This reduces power consumption as compared to mechanisms where power is required to maintain the state of the Braille dots at all times. Fig1 shows the mechanical principle of operation. Calculations indicate that the required dot height of 0.019\" and refresh rate of at least 7.5 characters/s can be easily achieved with the setup.

2.1.2 Removable memory

The purpose of a removable memory in this design is to store e-books. A micro-SD card will be used as removable memory. A microSD card is one of the smallest flash memory cards on the market today. Here SD stands for Secure Digital. Secure Digital or (SD) is a non-volatile memory card format for use in portable devices, such as mobile phones, digital camera, GPS navigation system etc. Most

technical measurements for the microSD card put it at 15x11x1. It is interfaced to the controller by SPI protocol, which is supported by the ATMEGA328 of the controller.

2.1.3 Wireless Bluetooth

The purpose of a wireless receiver in this design is to receive SMS data from a mobile device. The Bluetooth communication protocol was chosen since mobile devices can communicate wirelessly to close range peripherals via Bluetooth.

2.1.4 Sensor

The purpose of the capacitive touch sensor is to allow the user to scroll forward and backward through text (e-book or SMS). Also, the sensor should let user change books and finally toggle the SMS mode off after reading an SMS. The user interface consists of a left slider for scroll through text/SMS and a right slider for scrolling through book. The two sliders must be pressed together for greater than two seconds to toggle the SMS mode off.

The MPR121 Proximity Capacitive Touch Sensor Controller was used for the capacitive sensing from the capacitive pads. The operating voltage of this IC is from 1.71V to 3.6V. Thus, this IC was suitable for our 3.3V system. Also, this IC provides an I2C interface which is supported by the ATMEGA328 microcontroller. Finally the MPR121 IC has 12 channels of capacitive sensing for connection to 12 capacitive sensor pads. The capacitive touch surface is implemented on a PCB, with each copper pad serving as a touch surface. As seen in Fig 2 the sensor pads have been organized to 10 pads for vertical slider resolution and 2 pads interleaving the vertical pads for left or right slider press determination.

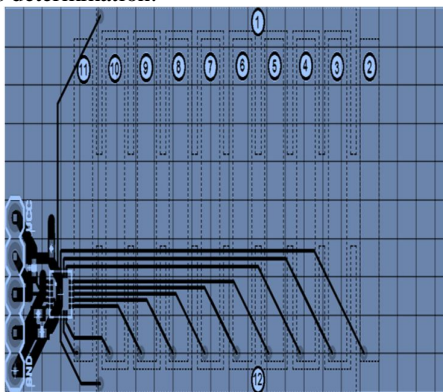

Figure. 2 PCB layout of capacitive sense board

2.1.5 Controller

Atmega328 is a AVR microcontroller that is developed by Atmel corporation. AVR is an 8-bit microcontroller belonging to the family of reduced instruction set computing(RISC).In RISC architecture the instruction set of the computer are not only fewer in number but also simpler and faster in operation compared to CISC architecture. The AVR core combines a rich instruction set with 32 general purpose working registers. All the32 registers are directly connected to the Arithmetic Logic Unit (ALU), allowing two independent registers to be accessed in one single instruction executed in one clock cycle. The resulting architecture is more code efficient while achieving throughputs up to ten times faster than conventional CISC microcontrollers.Fig3 shows the pictorial representation of controller used as sense board.

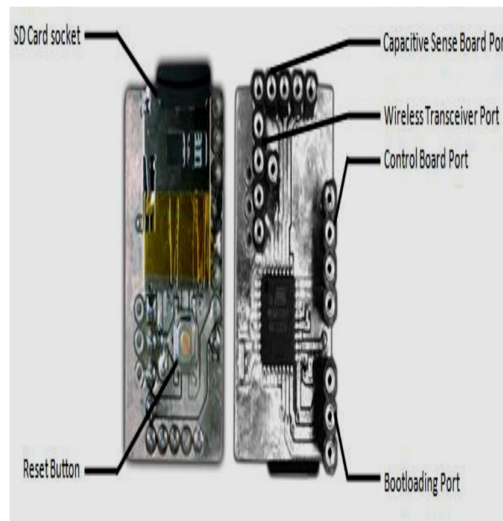

Figure. 3 sense board controller

2.1.6 Power supply

The power module consists of two 3.3V 1A voltage regulators, one 3.3V 500mA voltage regulator, a fuel gauging IC and a two-cell 7.4V rechargeable lithium-polymer battery (LiPo). The device is designed such that all modules are powered at 3.3V. This is because communication with the microSD card utilizes the SPI interface, which operates only at 3.3V while all other modules have a wider operating voltage range inclusive of 3.3V. If a different supply voltage is used, we would have to up and down-convert the voltage of the data signals on the SPI interface. Each one of the two 1A voltage regulators is responsible for powering six servos,

while the 500mA voltage regulator is responsible for powering all the other modules.

2.2 Software Architecture

In our proposed system we are working with ATMEGA microcontroller as this supports Arduino platform which is the efficient IDE tool uses simplified library functions of c/c++. It is inexpensive and can support windows, Mac OS x and Linux. It makes input/output operations much easier. Arduino is a open-source single-board microcontroller, descendant of the open-source Wiring platform, designed to make the process of using electronics in multidisciplinary projects more accessible.

The Arduino IDE is a cross-platform application written in Java, and is derived from the IDE for the Processing programming language and the Wiring project. It refers to an open-source electronics platform or board and the software used to program it. In essence, this platform provides a way to build and program electronic components. Arduino programming language is a simplified form of C/C++ programming language based on what Arduino calls "sketches," which use basic programming structures, variables and functions. These are then converted into a C++ program. Other open-source electronics prototyping projects, such as Wiring and Processing, provide the underpinnings for Arduino technology. As shown the fig 4 shows layout of Arduino board.

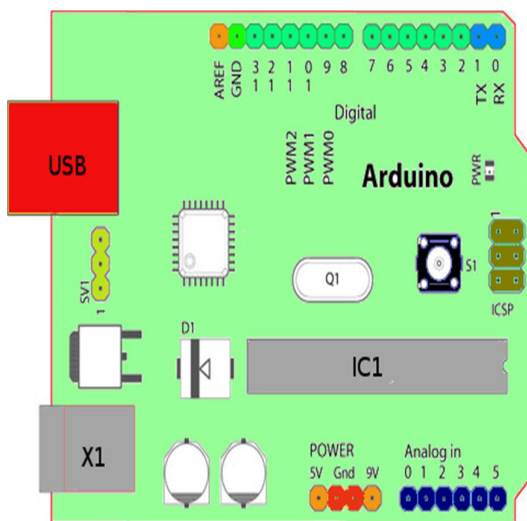

Figure. 4 Arduino board Specifications

Features of the Arduino platform include:

- i) Wide adoption and useful support from numerous websites, newsgroups, and user forums.
- ii) Extensibility through plug-in boards for a broad range of applications, such as motor control, wireless communication, audio processing, and data logging.
- iii) The Arduino IDE comes with a C/C++ library called "Wiring" (from the project of the same name), which makes many common input/output operations much easier. Arduino programs are written in C/C++, although users only need to two functions to make a run able program.
- iv) Setup () – a function run once at the start of a program that can initialize settings.
- v) Loop () – a function called repeatedly until the board powers off.

The Arduino IDE uses the GNU tool chain and AVR Library to compile programs, and uses AVR dudu to upload programs to the board.

3. OVERALL LAYOUT ANALYSIS

3.1 Braille Interface (BI)

BI.1: Braille cells to meet Braille size specifications as laid down by the National Library Service for the Blind and Physically Handicapped (NLS) [11]

- 0.057" (1.45mm) – dot base diameter
- 0.092" (2.34mm) – intracell dot spacing
- 0.245" (6.23mm) – intercell dot spacing (same line)
- 0.019" (0.48mm) – dot height

- i) Dimensions and placement of holes for Braille pins on top plate match specifications to within 5%.
- ii) CAD design of top plate matches the dimensions exactly.
- iii) Servo rotation produces vertical displacement of $0.019'' \pm 5\%$.
- iv) BI.2: At most 0.133s for Braille cell to refresh. Time includes:
- v) Microprocessor latency – moment from parsing of ASCII characters to sending of PWM signals.
- vi) Servo latency – moment from receiving PWM signal to moving pins to the desired height.

3.2 Controller (CO)

CO.1: Encodes alphanumeric characters into control signals for servos.

CO.2: Receives data from external sources.

- a) Removable memory – Serial Peripheral Interface Bus (SPI).
- b) Wireless transceiver – Serial Port Profile (SPP) or Host Controller Interface (HCI).
- c) Sensor – Inter-Integrated Circuit (I²C) interface.

CO.3: Performs gesture recognition on sensor data.

CO.4: Voltage gauging and auto shutoff.

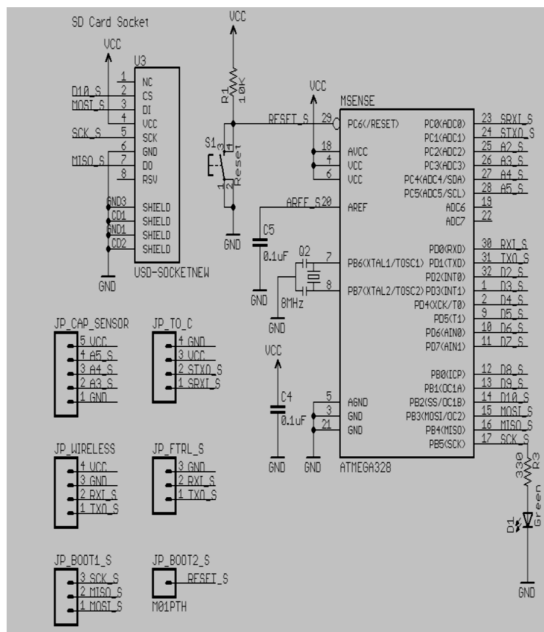

Figure. 5 Hardware Schematic

3.3 Sensor (SE)

SE.1: Each pad of capacitive touch sensor detects user touch.

Removable Memory (RM)

- RM.1: Read from memory with no errors.
- RM.2: Memory does not become corrupted with time and multiple accesses.

Wireless Transceiver (WT)

WT.1: Receives from Bluetooth devices that are at least 1m away with no errors.

Minimal radio interference

No electrical components, surface traces, GND planes or exposed biases are located below the transceiver's antenna and shielding connections.

3.4 Power Supply (PS)

PS.1: Provides 3.3V at 735mA throughout 1 hour of continuous operation.

PS.2: Rechargeable. PS.1 is still met after recharge.

4.RESULT

The hardware design architecture and the prototype code is to be designed and developed on the Arduino board consisting of megaAVR Atmega328 microcontroller with components to facilitate programming and incorporation into circuit design PCB design plays a very crucial role in development of the device. The size of the PCB is constrained by the size of our device. The figure below depicts a 3D model that gives an estimate on the size of our device. Only the servos, Braille top plate and LiPo battery are included since these are the components that take up the most space. It's clear from the diagram that our PCB should be no larger than 5cm X 4.1cm.

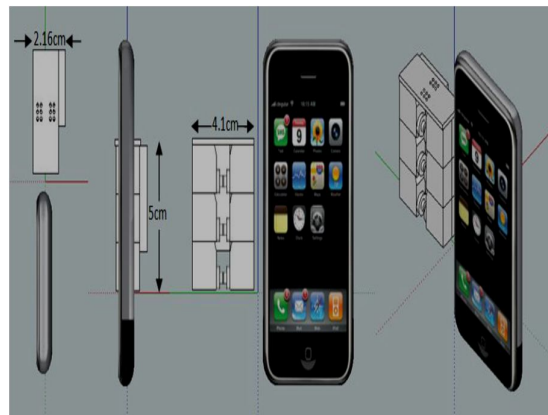

Figure. 6 3D Model

5. CONCLUSION

The messages and e-text in ASCII form would be converted into Braille text and hence we conclude that the blind get a chance to access and utilize the e-doc and web resources with ease and simplicity. The proposed portable device is powered up by rechargeable lithium polymer battery and executed on open source powerful software environment Arduino makes it easy to handle by the visually impaired users with their abilities.

Future work in this field can be trying to add an audio slot for better functioning of the device. This would make the system more easy to handle that



provides step by step instructions to access the internet and extract the technology to the maximum limit.

ACKNOWLEDGEMENT

Special thanks to our guide Mr. M.A.Raja, Assistant Professor, Department of ECE, Park College of Engineering and Technology.

REFERENCE

- [1]. Sunil Kumar M.E –Karnataka University Braille language learner for blinds International Journal Of infinite Innovations in technology 2012-2013Reg. No.:20120905|DOI:V1I2P05.
- [2]. Kumar J.A.V, Visu A , Raj M.S, Prabhu M.T, Kalaiselvi V.K.G ‘A pragmatic approach to aid visually impaired people in reading, visualizing and understanding textual contents with an automatic electronic pen ‘Computer Science Automation Engineering (CSAE), 2011 IEEE International Conference.
- [3]. Dias M.B, Dias M.F, Belousov S, Rahman M.K, Sanghvi S, Fanaswala I, Ghazzawi W, Abdulsalam A, El-Moughny N, Menon S.R “An automated Braille writing Tutor with multilingual exercises and educational games “Information and Communication Technologies and Development (ICTD), 2009 International Conference.
- [4]. Rantala, J.; Raisamo, R.; Lylykangas, J.; Surakka, V.; Raisamo, J.; Salminen, K.; Pakkanen, T.; Hippula, A. “Methods for presenting Braille Characters on a mobile device in with a touch screen and tactile devices” Haptics IEEE transactions vol-2 2009 .
- [5]. Ramiro Velazquez, Enrique Preza and Hermes Hernandez, ‘Making eBooks Accessible to blind Braille Readers’, in IEEE International workshop on Haptic Audio Visual Environments and their Applications, Ottawa, Canada, 2008, pp.25-29.
- [6]. Al-Salman, Y. Alohal, M. AlKahal, and A. AlRajih, 2007. “An Arabic Optical Braille Recognition System” in Proceedings of the First International Conference in Information and Communication Technology & Accessibility ICTA’07, Tunisia, pp. 81-86.
- [7]. Haihong Zhu, Mark G. Allen, Seong Hyok Kim, Xiaosong Wu , ‘Portable Pneumatically Actuated Refreshable Braille Cell’, The 14th International Conference on Solid-State Sensors, Actuators and Microsystems, Lyon, France, pp. 1409-1412, (2007).
- [8]. Sribunruangrit, N., C. Marque, C. Lenay, and O.Gapenne, ‘Graphic –User-Interface for people with severely impaired Vision in Mathematics class,’ in proc.26: Annual Int’l Conf. of the IEEE-EMBS, San Francisco, USA, 2004, pp.5145-5148.
- [9]. National Library Service for the Blind and Physically Handicapped (NLS) of the Library of Congress, (NLS Reference Circulars) Braille Literacy: Resources for Instruction, Writing Equipment, and Supplies. Arduino study source code with examples: <http://arduino.cc/playground/>.
- [10]. C. Moorey and I. Murray School of Electrical and Computer engineering Curtin University of Technology, Kent street Bentley Western australia-6102: ‘Electronic Design of a low-cost Braille Typewriter’.